

R-UTA - UTAZ

Energy recovery high efficiency dehumidifiers



R-UTAZ (Outdoor Unit)

The energy recovery high efficiency dehumidifiers R-UTA range have been designed to grant the complete control of temperature, humidity, the energy recovery and the fresh air treatment in the covered swimming pools or in other applications with very high internal loads. The R-UTA units can operate in environments up to 36°C and are able to manage up to 30% of fresh air.

The range includes 7 models, which covers airflows range from 1500 to 6000 m³/h.

The use of double-passage-cross-flow energy recovery allows to increase up to 30% the dehumidification capacity in comparison to the traditional dehumidifiers.

The use of the double passage in the energy recovery, in fact, allows the free sensible pre-cooling of the air near to the saturation point, giving so the possibility to the unit to work, basically, in latent load.

VERSIONS

R-UTAZ Version with temperature control: these versions are supplied with a remote condenser and are used in those applications where it is necessary the simultaneous control of temperature and humidity: Dehumidification mode: the internal condenser is activated; the unit dehumidifies and heats up the room temperature; Cooling mode: the remote condenser is activated; the unit dehumidifies and cools down the room temperature.

ACCESSORIES

- DBRC** Low ambient temperature device with heat recovery.
- PCRL** Remote control panel.
- RP01** Partial heat recovery Cu-Ni made.

R-UTA Models		015	020	028	035	042	052	060
Moisture removed ⁽¹⁾	l/24h	132,7	162,3	248,9	310,7	376,0	464,4	565,2
Moisture removed ⁽²⁾	l/24h	223,0	290,9	444,8	552,2	587,5	746,4	907,5
Nominal input power ⁽¹⁾	kW	1,97	2,54	3,44	5,27	5,86	7,74	9,94
Maximum input current	A	6,8	9,4	12,7	17,7	18,5	20,9	25,8
Hot water coil ⁽³⁾	kW	18	23	28	33	53	64	70
Total air flow	m ³ /h	1500	2000	2800	3500	4200	5200	6000
Available static pressure	Pa	200	200	200	200	200	200	200
Maximum fresh air flow	m ³ /h	450	600	845	1050	1260	1560	1800
Refrigerant		R410A	R410A	R410A	R410A	R410A	R410A	R410A
Sound pressure ⁽⁴⁾	dB (A)	63	63	66	66	68	69	69
Compressors / Circuits	n°/n°	1 / 1	1 / 1	1 / 1	1 / 1	1 / 1	1 / 1	1 / 1
Power supply	V/Ph/Hz	400/3+N/50	400/3+N/50	400/3+N/50	400/3+N/50	400/3+N/50	400/3+N/50	400/3+N/50

Performances are referred to the following conditions:

(1)Room temperature 30°C; relative humidity 60%, fresh air 0%.

(2)Room temperature 30°C; relative humidity 60%, fresh air 30% (-5°C 80%).

(3)Room temperature 30°C; water temperature 80/70°C, unit compressor in stand-by

(4)Sound pressure level measured at 1 mt from the unit in free field conditions according to ISO 9614.

R-UTAZ Models		015	020	028	035	042	052	060
Moisture removed ⁽¹⁾	l/24h	132,7	162,3	248,9	310,7	376,0	464,4	565,2
Moisture removed ⁽²⁾	l/24h	223,0	290,9	444,8	552,2	587,5	746,4	907,5
Cooling capacity ⁽³⁾	kW	3,5	4,7	6,5	8,3	10,0	12,2	14,0
Nominal input power ⁽¹⁾	kW	1,97	2,54	3,44	5,27	5,86	7,74	9,94
Maximum input current	A	6,8	9,4	12,7	17,7	18,5	20,9	25,8
Hot water coil ⁽⁴⁾	kW	18	23	28	33	53	64	70
Total air flow	m ³ /h	1500	2000	2800	3500	4200	5200	6000
Available static pressure	Pa	200	200	200	200	200	200	200
Maximum fresh air flow	m ³ /h	450	600	845	1050	1260	1560	1800
Refrigerant		R410A	R410A	R410A	R410A	R410A	R410A	R410A
Sound pressure ⁽⁶⁾	dB (A)	63	63	66	66	68	69	69
Compressors / Circuits	n°/n°	1 / 1	1 / 1	1 / 1	1 / 1	1 / 1	1 / 1	1 / 1
Power supply	V/Ph/Hz	400/3+N/50	400/3+N/50	400/3+N/50	400/3+N/50	400/3+N/50	400/3+N/50	400/3+N/50

Performances are referred to the following conditions:

(1)Room temperature 30°C; relative humidity 60%, fresh air 0%.

(2)Room temperature 30°C; relative humidity 60%, fresh air 30% (-5°C 80%).

(3)Room temperature 30°C; relative humidity 60%, fresh air 0% (35°C-50%), net sensible cooling capacity in the room.

(4)Room temperature 30°C; water temperature 80/70°C, unit compressor in stand-by

(5)Sound pressure level measured at 1 mt from the unit in free field conditions according to ISO 9614.

OPERATION PRINCIPLE

The hot and humid return airflow, moved by the fan (G), passes in the return filter (A), then across the first side of the energy recovery (B) where, crossing the cold air present on the other side, leaves part of its enthalpy. At this point part of the treated air (from 0% to 30%) is removed by the exhaust fan (C), while the remaining part

passes across the cold evaporating coil (D) where it is dried at the required level.

After the evaporator the cold and dried airflow is mixed with fresh air (from 0% to 30%) entered through the fresh air damper (E) and returned into the energy recovery for the second passage where, crossing the hot air present on the other side, it is warmed up. The airflow then passes across

the condensing coil (F) where it is post heated and finally sent into the swimming pool. In case the air discharge temperature is still too cold, the hot water temperature coil H (accessory) will provide to increase it up to the required level.

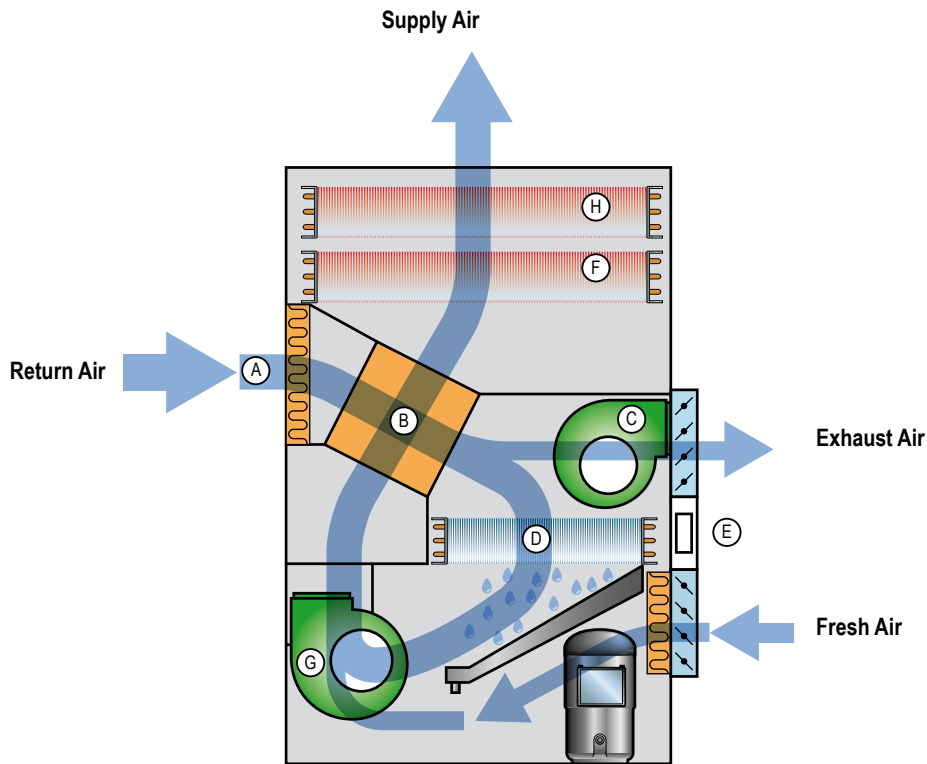

OPERATION LIMIT

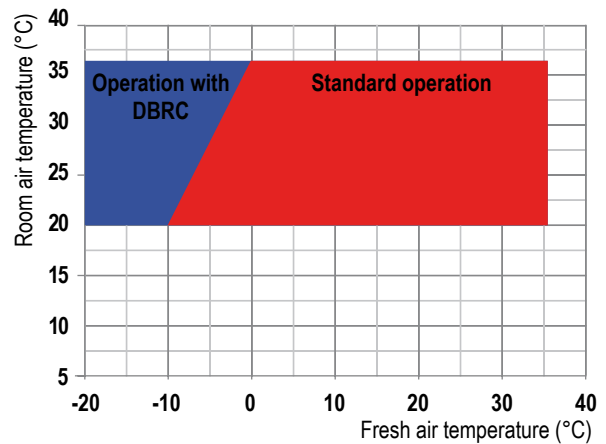
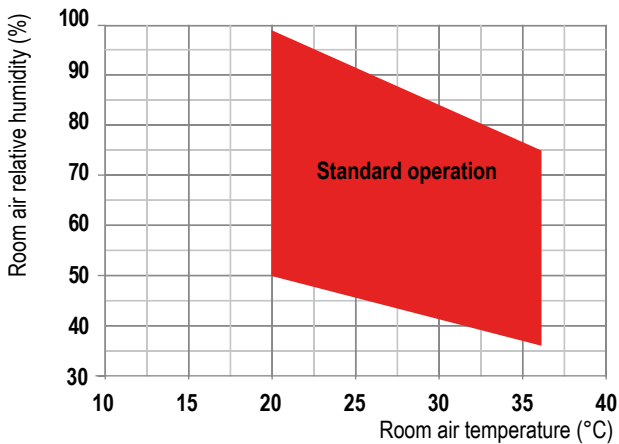

PLANT SCHEME WITH R-UTA

PLANT SCHEME WITH R-UTAZ

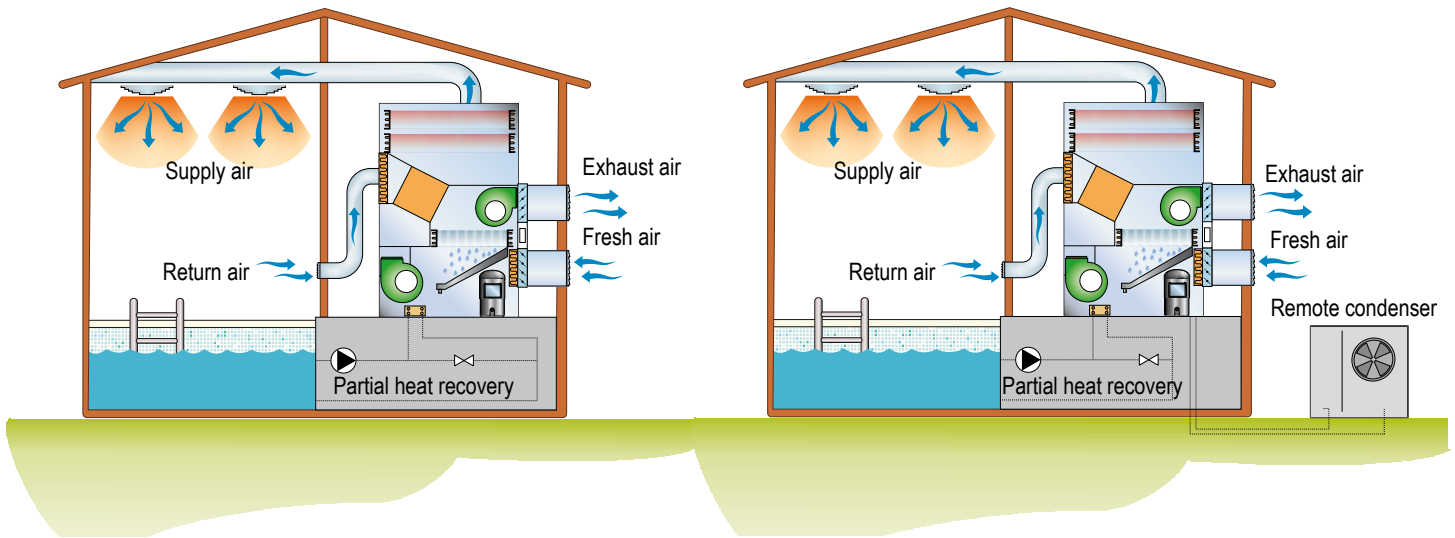

FRAME

All R-UTA units are made from hot-galvanized metal, painted with polyurethane powder enamel at 180°C to ensure the best resistance against the atmospheric agents and to operate in aggressive environments. The frame is self-supporting with removable panels. A stainless steel drip tray is installed on all units. The colour of the units is RAL 7035.

REFRIGERANT CIRCUIT

The refrigerant circuit is made by using international primary brands components and according to ISO 97/23 concerning welding procedures. The refrigerant gas used in these units is R410A. The refrigerant circuit includes: sight glass, filter drier, thermal expansion valve with external equalizer, liquid line manual shut-off valve, Schrader valves for maintenance and control, pressure safety device (according to PED regulation).

COMPRESSOR

The compressor is scroll type, with crankcase heater and thermal overload protection by a klixon embedded in the motor winding. The compressor is mounted on rubber vibration dampers and, upon request, can be supplied with sound-proof cover to reduce

noise emission (accessory). The crankcase heater, when present, is always powered when the compressor is in stand-by. The inspection is possible through the frontal panel of the unit that allows the maintenance of the compressor.

CONDENSER AND EVAPORATOR

Condensers and evaporators are made of copper pipes and aluminium fins. All coils are painted with epoxy powders to prevent corrosion problem due to their use in aggressive environments. The diameter of the copper pipes is 3/8" and the thickness of the aluminium fins is 0,1 mm. The tubes are mechanically expanded into the aluminium fins to improve the heat exchange factor. The geometry of these condensers guarantees a low air side pressure drop and then the use of low rotation (and low noise emission) fans. All units are supplied, standard, with a stainless steel drip tray and all evaporators are supplied with a temperature sensor used as automatic defrost probe.

HEAT RECOVERY

The heat recovery is cross flow heat exchanger type, with painted aluminium plates; painted galvanised steel frame with additional tightening of the heat exchange pack, in order to operate in aggressive

environments; it has a low pressure drop value and it is always supplied with stainless steel drip tray.

HOT WATER COIL

The hot water coil is made of copper pipes and aluminium fins. The diameter of the copper pipes is 3/8" and the thickness of the aluminium fins is 0,1 mm. The tubes are mechanically expanded into the aluminium fins to improve the heat exchange factor. All coils are supplied with a built-in 3 way modulating valve, directly managed by the microprocessor of the unit.

E.C. SUPPLY FAN

The supply fan is a high performance centrifugal type, double inlet forward curved blades, directly coupled to the electric motor. The fan wheel and the scroll are made from hot galvanised thick sheet metal, painted with polyurethane powders, to ensure the best resistance against aggressive environments. The electric motor is a high efficiency DC brushless type with external rotor, to guarantee an ideal cooling of the windings and the absence of power lost due to pulleys and belt transmission. The fan is statically and dynamically balanced class 6,3 according to ISO1940. The electric motor has a separate electronic com-

muter (driver) and a speed modulation 0-10V, integrated PFC, burn out thermal protection (in case of considerable reduction of the power supply), protection degree IP54, serial interface card with modbus protocol RTU.

E.C. EXHAUST FAN

The exhaust fan is a high performance centrifugal type, double inlet forward curved blades, directly coupled to the electric motor. The fan wheel and the scroll are made from hot galvanised thick sheet metal, painted with polyurethane powders, to ensure the best resistance against aggressive environments. The electric motor is a high efficiency DC brushless type with external rotor, to guarantee an ideal cooling of the windings and the absence of power lost due to pulleys and belt transmission. The fan is statically and dynamically balanced class 6,3 according to ISO1940. The electric motor has a separate electronic commutator (driver) and a speed modulation 0-10V, integrated PFC, burn out thermal protection (in case of considerable reduction of the power supply), protection degree IP54, serial interface card with modbus protocol RTU.

EXHAUST AND FRESH AIR DAMPERS

The exhaust and fresh air dampers are made of aluminium frame and fins, distance between the fins 150 mm. The bushes are in nylon; exhaust and fresh air dampers are connected each other and supplied already with servomotor managed by the microprocessor of the unit.

AIR FILTER

It's supplied standard with the unit. It's made of filtering material in synthetic fibre without electrostatic charge. It can be removed for differential disposal, class G5, according to EN 779:2002.

MICROPROCESSOR

All UTA units are supplied standard with microprocessor controls. The microprocessor controls the following functions: compressor timing, automatic defrost cycles, the management of fresh and exhaust air, post

heating valve and alarms. An appropriate LCD display shows the operation mode of the unit, set point and alarms.

BUILT-IN TEMPERATURE/HUMIDITY ELECTRONIC PROBE

It is installed, standard, on all UTA units. It is installed on the return air side and allows the unit to operate in dehumidification or heating depending on the required parameters. The electronic probe allows the showing of temperature and humidity values with an operating range from 0-50°C, humidity from 10-90%.

ELECTRIC BOX

The electric switch board is made according to electromagnetic compatibility norms CEE 73/23 and 89/336. The accessibility to the board is possible after removing the front panel of the unit and the OFF positioning of the main switch. In all R-UTA units are installed, standard, the compressors sequence relay which disables the operation of the compressor in case the power supply phase sequence is not the correct one (scroll compressors in fact, can be damaged if they rotate reverse wise). The following components are also standard installed: main switch, magnetic-thermal switches (as a protection of pumps and fans), compressors fuses, control circuit automatic breakers, compressor contactors, fan contactors, pump contactors. The terminal board is also supplied with voltage free contacts for remote ON-OFF.

CONTROL AND PROTECTION DEVICES

All units are supplied with the following control and protection devices: defrost thermostat, which signals to the microprocessor control that a defrost cycle is needed and controls its termination, high pressure switch with manual reset, low pressure switch with automatic reset, high pressure safety valve, compressor thermal overload protection, fans thermal overload protection.

ACCESSORIES

DBRC - LOW AMBIENT TEMPERATURE DEVICE

The low ambient temperature device is used when the fresh air temperature is lower than -5°C and allows the correct operation of the unit with very low ambient temperatures (down to -30°C). The device is made of a heat recovery composed by 2 water+ glycol coils connected with a water pump. The upper coil recovers the thermal load of the exhaust air, the mixture (glycol + water) in the coil is warmed up, then it is moved to the lower coil where the thermal load is transferred to the fresh air that is pre-heated before entering in the unit. The use of this device allows two advantages:- An additional heat recovery on the exhaust air increasing then the unit energy efficiency,- The fresh air inlet is suitable for the correct operation of the internal components.

The device is managed by the unit microprocessor and it is factory set; The operation mode is the following: When the fresh air sensor measures a temperature lower than -5°C it is activated the water pump so the heat recovery function. The device is in operation until the fresh air temperature raises above the minimum set point temperature (set in the microprocessor). The microprocessor, with a compared measures of temperature and humidity sensors, provides to switch off the compressor in case the fresh air conditions are suitable to guarantee the required indoor conditions. In this way it is reduced the energy consumption of the unit that operates in FREE COOLING MODE.

PCRL - REMOTE CONTROL PANEL

This panel can be mounted up to 50m (maximum) from the unit and replicates all of the control functions.

RGDD - BUILT IN-ELECTRONIC SENSOR (TEMP.+HUMIDITY)

Built-in Electronic temperature and humidity probe.

R-UTA Models	Code	015	020	028	035	042	052	060
Partial heat recovery Cu-Ni made	RP01	○	○	○	○	○	○	○
Low ambient temperature device with heat recovery	DBRC	○	○	○	○	○	○	○
Remote control Panel	PCRL	○	○	○	○	○	○	○
High efficiency E.C. fans ≤ 300 Pa	VECE	●	●	●	●	●	●	●

● Standard, ○ Optional, – Not Available.

R-UTAZ Models	Code	015	020	028	035	042	052	060
Partial heat recovery Cu-Ni made	RP01	○	○	○	○	○	○	○
Low ambient temperature device with heat recovery	DBRC	–	–	–	–	–	–	–
Remote control Panel	PCRL	○	○	○	○	○	○	○
High efficiency E.C. fans ≤ 300 Pa	VECE	●	●	●	●	●	●	●
Outdoor unit with condensation pressure control	CN	●	●	●	●	●	●	●

● Standard, ○ Optional, – Not Available.

RP01 - PARTIAL HEAT RECOVERY

The unit is fitted with a Coaxial type heat exchanger suitable for chlorinated water. The internal pipe is manufactured from Cupronickel with the external pipe being made from Copper. The chlorinated water flows

within the internal pipe whilst the refrigerant gas passes through the gap between the internal and external pipes. The Cupronickel internal pipe is manufactured with a special profile that generates turbulent flow within the refrigerant gas thus increasing

the heat exchange factor, the thermal efficiency and reducing the dimensions. The heat exchanger is designed to recover approx. 20% of the thermal capacity generated by the unit.

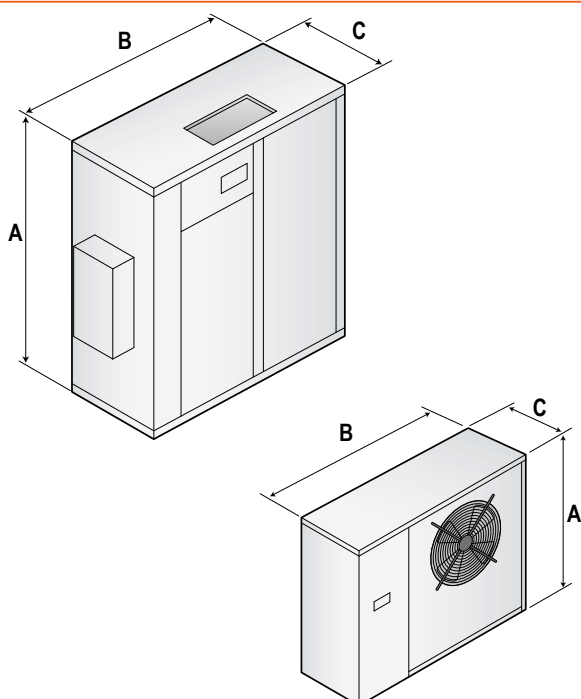

R-UTA - UTAZ (INDOOR UNIT)

Mod.	A (mm)	B (mm)	C (mm)	Kg
015	1770	1000	640	290
020	1770	1000	640	305
028	1850	1500	750	400
035	1850	1500	750	420
042	1950	1950	1250	570
052	1950	1950	1250	590
060	1950	1950	1250	620

OUTDOOR UNIT (R-UTAZ ONLY)

Mod.	A (mm)	B (mm)	C (mm)	Kg
015	989	1103	380	80
020	989	1103	380	80
028	1324	1203	423	92
035	1324	1203	423	92
042	1324	1203	423	92
052	1423	1453	473	130
060	1423	1453	473	130